



_The world of powder handling

Customized solutions for the pharmaceutical, chemical, healthcare and cosmetic industry



_Company

Novindustria AG in Switzerland is one of the leading suppliers of customized powder handling solutions for the pharmaceutical, chemical, healthcare and cosmetic industry. As dosing and handling specialist, we have made our mark in the industry with pioneering developments since early beginning in the 1960's. Equipment and systems «Made by Novindustria,» complies with applicable Hygienic, FDA, GMP and ATEX standards and guidelines.

Swiss quality and know-how

Extensive experience in the development, implementation and commissioning of first-class powder handling equipment and machinery, motivated staff and comprehensive services make Novindustria the ideal partner for your business.

Proven process and system solutions for dosing, filling, emptying and handling of powders and bulk materials.





_Process design and technology development

Our experience shows that bringing together your idea and Novindustria's technology and solution expertise leads to the best, most industrially feasible and economical production processes.

We perform dosing, discharging, filling, emptying and quality tests in our laboratory for customers and material suppliers.

- _Process optimization in functionality, efficiency and suitability for industrial use
- _Dosing and discharge tests
- _Filling or emptying tests (powder handling)
- _Recommendations for packaging and material choices
- _Definition and testing of optimal closing technology
- _Customer-specific technology development
- _Prototypes & and pilot line construction

Powder handling «made by Novindustria» brings together people and products, technology and solutions.

_Integrated solutions

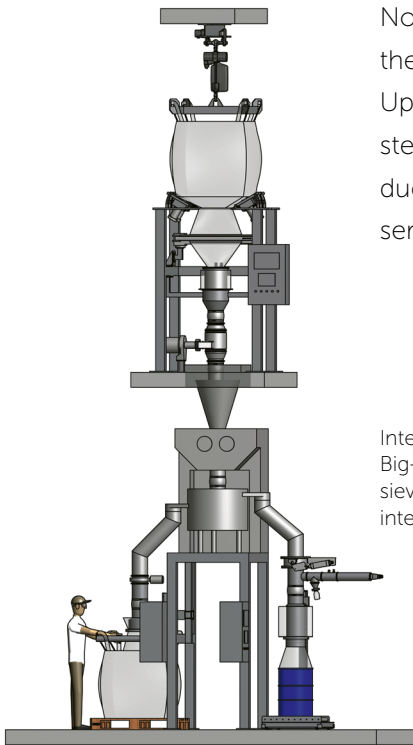

Novindustria assumes the entire project, from functional definition, the purchasing system, commissioning and handover to production. Upon request, we integrate upstream and downstream production steps from the dryer runs to automatic palletizing to a complete production process. After handover to production, we offer multiple services to take full advantage of the system during its entire lifecycle.

Integrated production process:
Big-Bag emptying with containment-foil, homogenization, compaction, control sieving, Vibro-Dos®, sampling, endless-foil and Big-Bag filling, weighing technology, integrated equipment and process control

Your ideas and our motivation – implementing joint success.

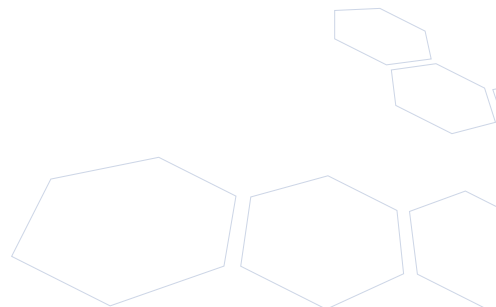
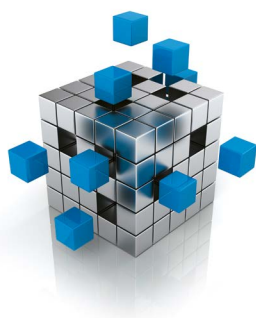

_Dosing and discharge devices

Hard-to-use products require proper functionality for dosing and discharging. In choosing the optimal dosing and discharging equipment, the highest precision, repeatability, maximum product protection, easy disassembly, easy cleaning and maximum hygiene are the decisive criteria. The Novi-Dos® and the Vibro-Dos® from Novindustria are two proven and versatile dosing and discharge devices.

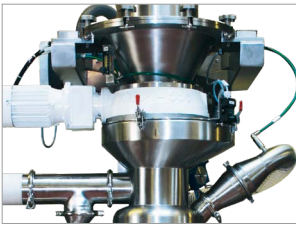

Novi-Dos®

- _Fluidisator sword for gentle product mobilization
- _Especially suitable for difficult-to-flow and blunt products
- _Best dosing precision thanks to short reaction times of pivoting arm



Vibro-Dos®

- _Compact and space-saving installation
- _Few product-impacting parts
- _Integrated turbine vibrators for gentle product mobilization
- _Especially suitable for difficult-to-flow products
- _Best dosing precision thanks to short reaction times of butterfly valve

_Filling

Safe, precise and clean filling of simple and difficult to dose powder places high demands on each component. Smooth interaction between process, function and technology, combined with our years of experience in powder handling are decisive criteria for reliability, quality and equipment availability.

We offer fixed, mobile and combined filling equipment for:

- _Big-Bags, drums, boxes with/without in-liners
- _Single bags made of different material (PE, PA, PP, paper, laminates, etc.)
- _Endless- as well as containment-foil
- _Container
- _Other types of packaging



Single bag filling with Novi-Dos®



Mobile endless-foil filling station with Vibro-Dos®



Big-Bag filling with conveyor and product compression

_Emptying

A wide variety of product properties requires the use of the latest technologies as well as proven, safe and clean emptying of small packaging, Big-Bags and containers.

We offer field-proven know-how, profound experience in emptying dusty, aggressive and harmful products with different flow characteristics.

We offer fixed, mobile and combined emptying equipment for:

- _Big-Bags, drums, boxes with/without in-liners
- _Containment-foil solutions
- _Single bags made of different material (PE, PA, PP, paper, laminates, etc.)
- _Container
- _Other types of packaging



Big-Bag emptying with endless-foil system in a glove box



Big-Bag emptying on weighing cells with docking systems and rotary valve



Single bag emptying with pressure sluice, glove box, bag-out system, lump breakers and pneumatic conveying

_Containment

Novindustria offers containment solutions from simple, low-dust powder handling equipment (OEB 1&2) to innovative endless-foil systems (OEB 3&4) to sterilized filling and dosing in the isolator for highly toxic products (OEB 5 & up). We deliver crucial highest standards for personal and product protection.

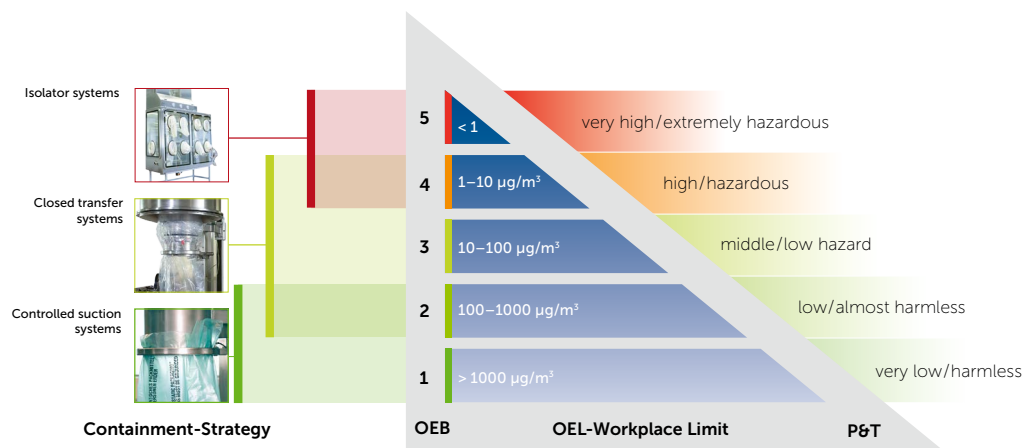

OEB – Occupational Exposure Band
 OEL – Occupational Exposure Limit
 P&T – pharmacologic & toxic impact



Dosing and filling system with endless-foil and thermal cutting/welding equipment in the isolator



Endless-foil filling equipment with Vibro-Dos®, pneumatic clipper, balance and conveyor



SMART Containment – peelable containment-foil, exclusively available from Novindustria

_Closure systems

For a package with the highest standards for quality, safety and tightness, the precise interaction of production process, powder characteristics, packaging material, closing technology and resulting Occupational Exposure Limit – is crucial. With thermal and mechanical closing systems «Made by Novindustria» flexible packages can be manually as well as automatically closed.



Thermal cutting/welding unit



Mobile thermal welding machine



Pneumatic clipper



Containment closure



Novi-Binder

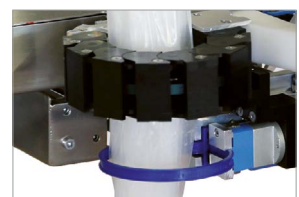

Automatic Novi-Binder

We offer extensive and in-depth knowledge – take advantage for your long-term success.

_Software and control skills

Smooth interaction between process, mechanical, electrical engineering and control in a reliable, functional system is absolutely crucial. With our own «in-house» control and software skills we are able to offer the appropriate control solution for customized equipment. Our specialists develop and program custom-made software and our experienced automation engineers implement the processes in our own control and electrical cabinets.

The «in-house» control systems developed by Novindustria guarantee fast and smooth start-up, and contribute to future modifications and improvements.



_Novindustria Services

Novindustria Services is composed of a highly motivated and qualified team of service engineers. We focus our work on tailor-made services, fast on-site support, continuous optimization of production processes, equipment technology and equipment availability.

At Novindustria

_Spare parts

Original spare parts and spare parts management

_Help line

Telephone support by qualified service technicians

_Remote support

Remote diagnosis or remote maintenance with secure modem connections to system controls

_Training

Staged and hands-on training of operators and technicians from operations and maintenance

At your site

_Commissioning and training

Commissioning as well as staged and hands-on practical training of operators and service technicians from operations and maintenance

_Support

Troubleshooting by the Novindustria service team

_Check-ups and maintenance

Analysis of system status, revision and maintenance with and without maintenance contracts

_Optimization

Analysis of downtime to increase efficiency, system performance and process optimization

_Retrofit

Upgrade and modification of your system to meet new needs and technologies (such as software updates, latest dosing technology, improved performance, new types of packaging, etc.)

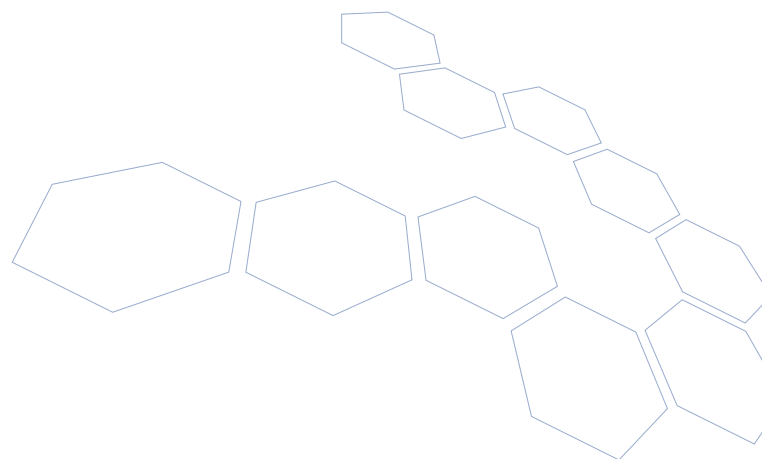

novindustria

Powder Handling Technology

Novindustria Containment AG

Gewerbstrasse 1

4450 Sissach

Switzerland

Tel. +41 61 976 70 70

info@novindustria.com