

_Bag-Out System equipped with the Novi-BagOut Liner



The specially designed Bag-Out system from Novindustria was developed for simple, safe and closed entry and removal of bags, small containers, contaminated clothing and waste products. Installed in a cleanroom wall, a staff air lock, an isolator or a glove box, the snap closure with a hinged lid can be conveniently opened and closed by hand. For complete closed liner exchange, the liner holder is equipped with a proven Safe-Change-System. The Novi-BagOut Liner is offered in a film length of up to 40 metres, depending upon the size.

Your benefits

- _Deployable in cleanrooms (single or double-walled system), staff airlocks, isolators, glove boxes, etc.
- _Completely closed inward and outward product transfers
- _Bag-Out System, Novi-BagOut Liner and closure device from one source
- _Novi-BagOut Liner up to 40 metres film length
- _Simple and secure single-handed operation
- _Completely closed liner exchange thanks to the proven Safe-Change-System.

THE ORIGINAL: THE FUTURE

_Technical data

DN	Ø A [mm]	C [mm]	E [mm]	Material	Novi-BagOut Liner		
					[Length/Thickness]	Height	[Material]
350	495	290	600	<ul style="list-style-type: none"> > AISI 304/304L (1.4301) > Lid: POM-C white > Hinge: Plastic 	≈ 40m/60µm	≈ 250	<ul style="list-style-type: none"> > Polyethylene (PE) > 5% anti-static > Non FDA-compliant
500	645		750	<ul style="list-style-type: none"> > Fast closure: Stainless steel 	≈ 30m/75µm		

Other sizes, materials and liners available upon request

ATEX: Zone 1, 2, 21, 22 (lid made of black PE-UHMW, electrically conductive $< 10^6 \Omega$, with earthing)

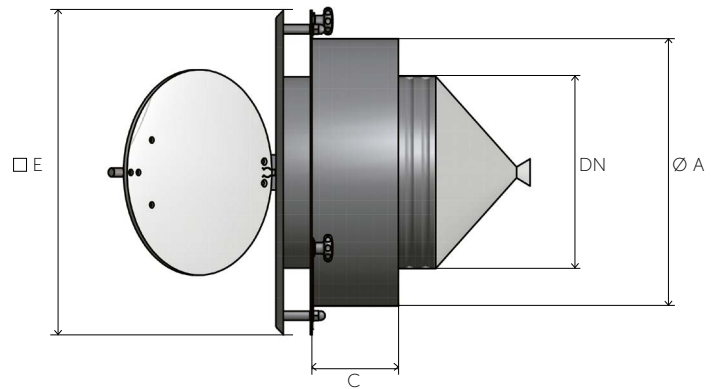
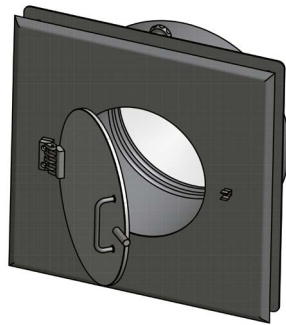

Process



Removing product



Close the liner



Cut the liner and dispose of the removed product

Closure systems

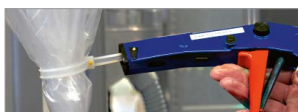

Containment closure



Cutting-Tool



Thermal cutting/Welding unit



Pneumatic clipper