

_ Bag-Out System Compact equipped- with the Novi-Compact Liner



The Bag-Out System Compact was designed for simple, secure and closed entry and removal of bags, small containers, contaminated clothing and waste products. Installed in a cleanroom wall, a staff air lock, an isolator or a glove box, the snap closure with a hinged lid can be conveniently opened and closed by hand. For complete closed liner exchange, the liner holder is equipped with a proven Safe-Change-System. The Novi-Compact Liner is offered in a film length of up to 110 metres, depending upon the size.

Your benefits

- _ Deployable in cleanrooms (single or double-walled system), staff airlocks, isolators, glove boxes, etc.
- _ Completely closed inward and outward product transfers
- _ Bag-Out System, Novi-Compact Liner and closure device from one source
- _ Novi-Compact Liner up to 110 metres film length
- _ Simple and secure single-handed operation
- _ Completely closed liner exchange thanks to the proven Safe-Change-System.

THE ORIGINAL: THE FUTURE



_Technical data

DN	Ø A [mm]	C [mm]	E [mm]	Material	Novi-Compact Liner		
					[Length/Thickness]	Height	[Material]
300	395	230	500	<ul style="list-style-type: none"> > AISI 304 / 304L (1.4301) > Lid: POM-C white > Hinge: Plastic > Fast closure: Stainless steel 	≈ 45m/25µm	≈ 130	<ul style="list-style-type: none"> > Polyethylene (PE) > not anti-static > non-FDA-compliant
350	495		600		≈ 85m/22µm		
400	595		700		≈ 110m/25µm		

Other sizes, materials, liners and ATEX zones available upon request

ATEX: Zone 2, 22, 21 (lid made of black PE-UHMW, electrically conductive <math>< 10^6 \Omega</math>, with earthing)

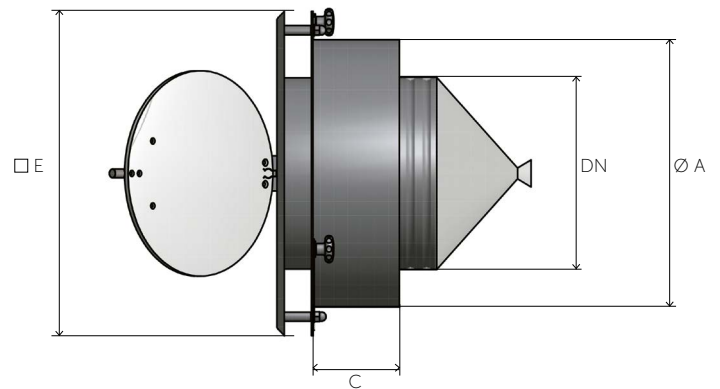
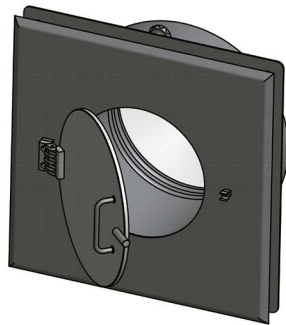

Process



Removing product



Close the liner



Cut the liner and dispose of the removed product

Closure systems



Containment closure



Cutting-Tool



Thermal cutting/Welding unit



Pneumatic clipper